

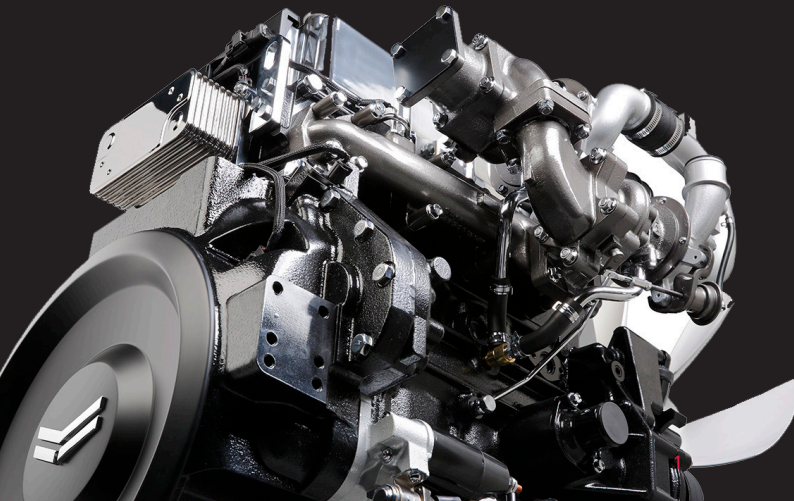

YANMAR

INDUSTRIAL ENGINES

***Water-Cooled
Diesel Engines
5-155 kW***



Our Partnership Has No Downtime



CONTENT

YANMAR WATER-COOLED ENGINES	4
ENGINE TECHNOLOGY	6
Common Rail technology	6
Diesel Particulate Filter (DPF)	6
Cooled Exhaust Gas Recirculation (EGR)	6
Selective Catalytic Reduction (SCR)	8
Intercooler	9
Electronic Control Unit (ECU)	9
POWER PACKS	9
HIGH POWER TN-SERIES	10
TN-SERIES OVERVIEW	14
ENGINES < 19 KW	16
ENGINES FROM 19 - 56 KW	29
ENGINES > 56 KW	45
5 YEAR WARRANTY	51
YANMAR SPARE PARTS	52
Air Filters	52
Fuel Filters	52
Oil Filters	53
Engine Oil	53
Coolant	54
Yanmar Ready to use Filter Kits	55

YANMAR WATER-COOLED ENGINES

Yanmar engines are the focal point and the heartbeat of any construction project – whatever the challenges. Yanmar's engines provide machine operators with a host of benefits such as reliability, durability, low lifecycle costs and low emissions capabilities which meet all global regulations.

With a philosophy of providing leading-edge technology to operators, Yanmar's engine range is trusted to deliver excellence.

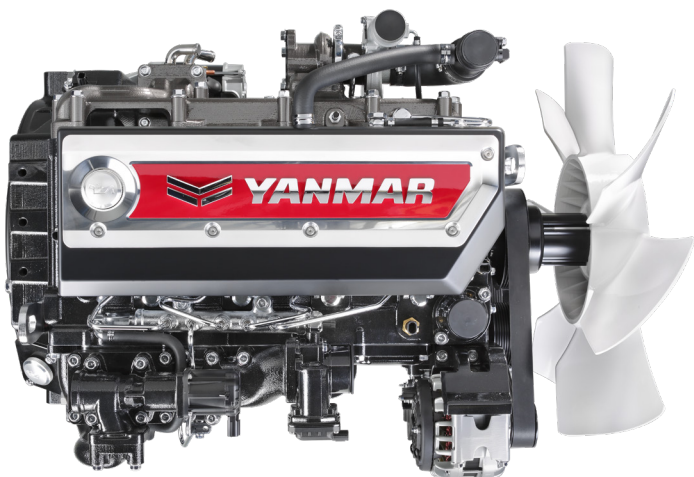

Main Features:

- **Unbeatable Fuel Consumption.** State-of-the-art combustion technology based on decades of detailed research has resulted in engines which achieve fuel consumption reductions of approximately 10% compared with competing engines. That provides a host of benefits to the machine operator such as significant financial savings and longer operational times.

- **Maximizing Uptime.** Reducing emissions to meet all worldwide regulations is at the forefront of Yanmar's engine development. Ensuring the engines to work seamlessly and continuously in an array of demanding environments across the globe.
- **Compact Dimensions.** The compact, space-efficient dimensions of Yanmar's engines satisfy the diverse demands of machine manufacturers and eases the installation process. The profile and visibility of machines and also operator comfort are enhanced by Yanmar's leading edge, proprietary exhaust gas reduction technology resulting in a more compact exhaust gas after-treatment system.
- **Wide Power Range.** Customers can use Yanmar engines in an extensive range of machines which each have their own various output requirements.
- **Outstanding Torque.** Yanmar's advanced combustion technology and turbocharger expertise means its engines deliver exceptional torque to satisfy the demands of diverse industrial applications such as construction, material handling and agriculture.

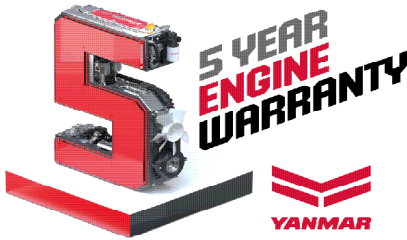

YANMAR 5-YEAR WARRANTY

With a Yanmar engine inside your equipment, your business is unstoppable. And with our free of charge 5-Year warranty (or 5,000 operating hours) we guarantee peace of mind and optimal continuity.

More info? Visit our website: www.yanmar.com/eu/industrial/5-year-warranty

ENGINE TECHNOLOGY

The latest generation Yanmar water-cooled diesel engines are equipped with a variety of state-of-the-art technologies that help achieve optimal performance and conformity to local and international emission standards.

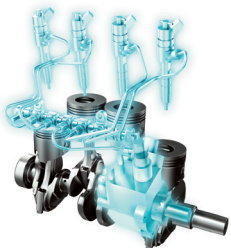

Common Rail Technology

A high-pressure, electronically-controlled, multi-stage, Common Rail fuel injection system is at the heart of quiet and fuel efficient Yanmar engines, cutting exhaust emissions of nitrogen oxides and particulate matter.

Diesel Particulate Filter (DPF)

Yanmar's engines include a DPF system to catch particulate matter contained in the exhaust gas. The particulate matter trapped inside the DPF is processed when the DPF automatically regenerates, keeping the filter constantly clean.

DPF has a seamless three-step regeneration control system that enables regeneration even in low-speed low-load operations:

- **Assist Regeneration**
- **Reset Regeneration**
- **Stationary Regeneration**

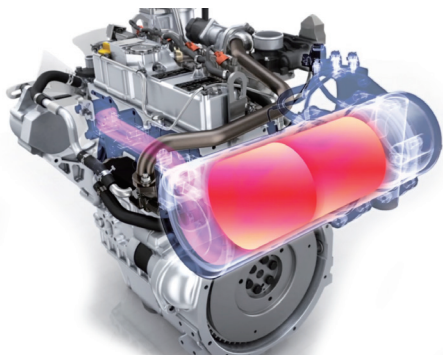

The unique Yanmar DPF technology allows a guaranteed minimum of 6,000 hours maintenance-free operation, which comes down to a lifetime of maintenance-free operation in the vast majority of applications.

Cooled Exhaust Gas Recirculation (EGR)

Engines equipped with a cooled EGR recirculate some of the exhaust gas back into the air intake. This reduces NOx emission by controlling the oxygen concentration in the combustion chamber and reducing the combustion temperature.

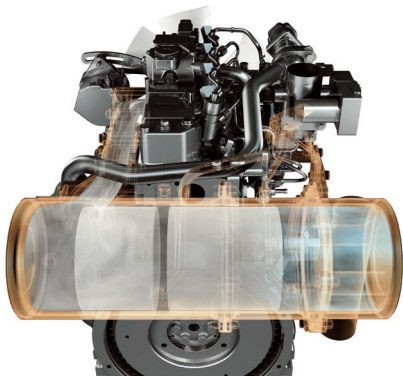

The circulated exhaust gas is cooled by the EGR cooler and its volume flow is electronically controlled by the EGR valve, depending on the engine operation state.

The result: ideal combustion conditions that in turn improve the performance and reduce the emission of the engine.

Selective Catalytic Reduction (SCR)

Yanmar engines above 56kW are equipped with a selective catalytic reduction (SCR) system. SCR is an advanced active emissions control technology system that reduces tailpipe emissions by injecting a urea solution into the exhaust gas.

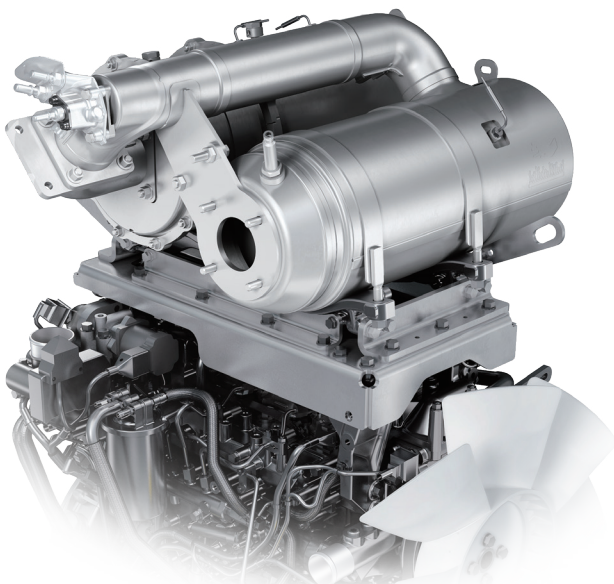

This solution reacts with the NO_x through catalytic reduction. Resulting in non-toxic nitrogen and water that can be discharged into the open air.

Electronic Control Unit (ECU)

At the heart of Yanmar's engines is the ECU - which provides the brainpower to offer unparalleled performance and insights into engine operation.

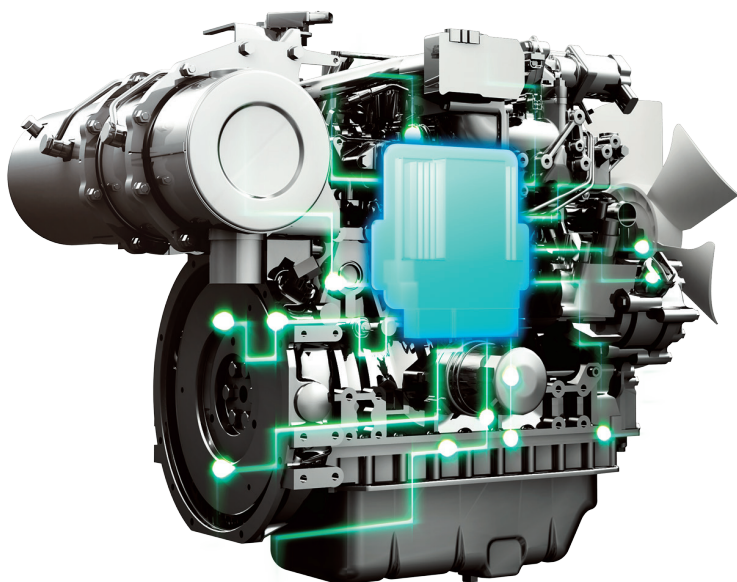

The ECU uses the collected data from several sensors on and around the engine to guarantee the most optimal performance and emission compliance.

Intercooler

Some Yanmar engines are equipped with an intercooler, which cools hot air from the turbocharger before it enters the engine, increasing the amount of oxygen to achieve higher performance.

POWER PACKS

The Yanmar Power Packs integrate Yanmar's original diesel engines technologies in an easy-to-use package. The Power Pack is designed to be a plug and play solution to fit several different applications.



The compact but powerful, reliable Power Pack provides durable performance, high quality and versatility, while keeping the fuel efficiency and environmental friendliness.

■ Easy Maintenance

Yanmar Power Packs are designed with ease of maintenance in mind. Maintenance parts are easily accessible to minimize downtime.

■ Plug and Play

The Yanmar Power Pack is available in a number of different Plug and Play configurations to fit a variety of applications, and to meet the requirements of different customers.





HIGH POWER TN SERIES

The Yanmar engine range goes up to 155kW with the high power TN series.

■ Best in Class Fuel Consumption

By implementing our advanced combustion technology, which has been cultivated through years of manufacturing industrial and marine diesel engines, our engines achieve fuel consumption reductions of approximately 10% compared to a similar size engines with the same output.

The improvement in fuel efficiency results in longer operation times and contributes to significant financial savings throughout the life-cycle of the engine.

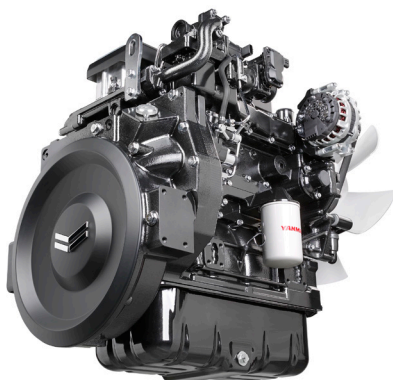

■ High Power Density

Yanmar developed a high-rigidity engine designed for high-power output. The 4TN107 features a two stage turbocharger that gives it a class-leading power density of 34 kW/L.

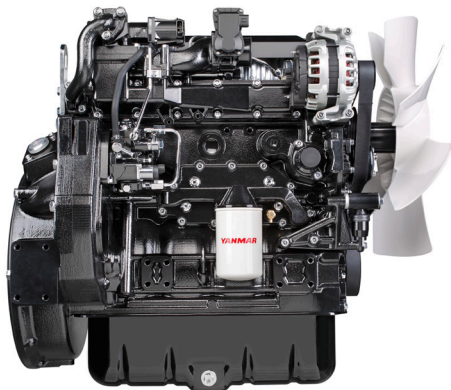

■ Wide Power Range

The 4TN101 and 4TN107 produce outputs ranging from 85 to 105 kW and 90 to 155 kW, allowing our customers to utilize their engine in a wide range of machinery with various output needs.

■ Compact Size

The compact profile of the engine takes into account the needs of vehicle manufacturers and improves the installation characteristics.

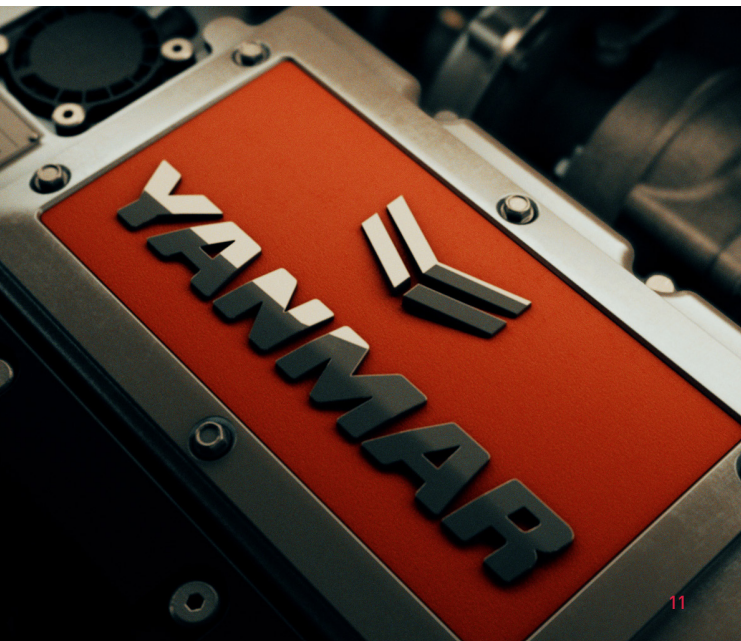

Yanmar's proprietary exhaust gas reduction technology results in an exhaust gas after treatment system with improved outward visibility and comfort level for machine operators.

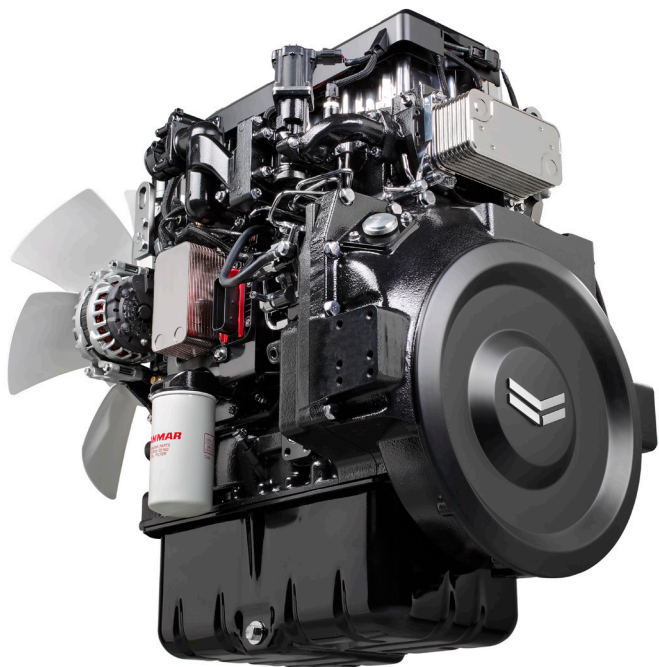

■ Maximize Uptime

Yanmar's engines utilize a Diesel Particulate Filter (DPF) technology and a Selective Catalytic Reduction (SCR) system to reduce harmful emissions. These technologies cause the 4TN101 and 4TN107 to comply with world wide emission regulations.

Ensuring our customers to continue to operate their vehicles without having to stop, even at high-altitude, low-temperature or when working with light or heavy loads.

■ Outstanding Torque

Thanks to Yanmar's advanced combustion technology and application of the turbocharger, both engines deliver superior torque that allows them to meet the requirements of a wide variety of industrial applications (e.g. construction, agriculture and material-handling).

Furthermore, the 4TN107 with a two stage turbocharger can achieve a maximum torque of 805 Nm.

WIDE POWER RANGE

4TN101

105kW



55kW

155kW

4TN107

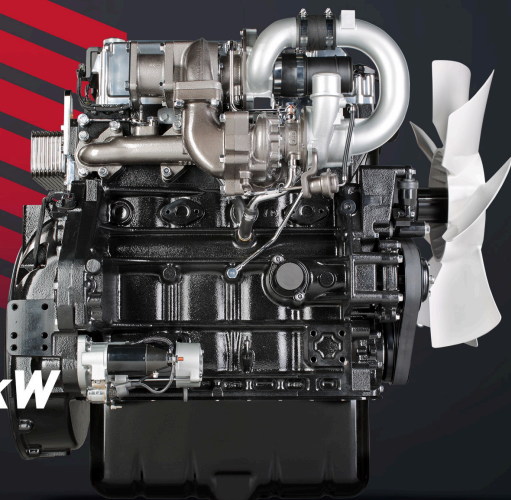

90kW

< 19 kW

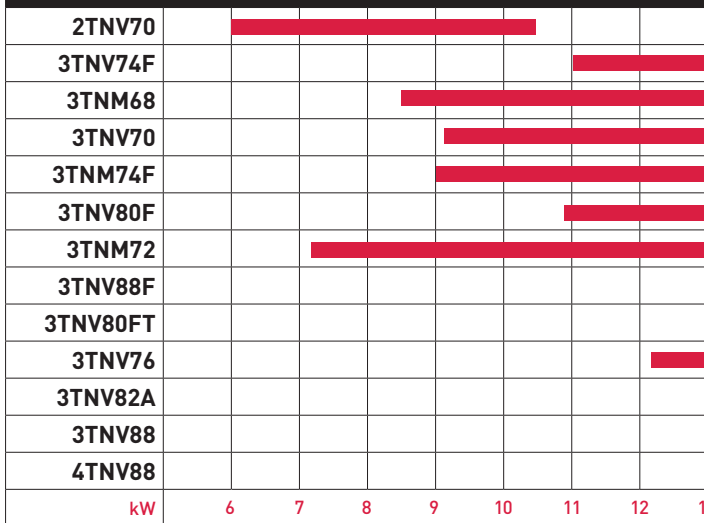

19 kW - 56 kW

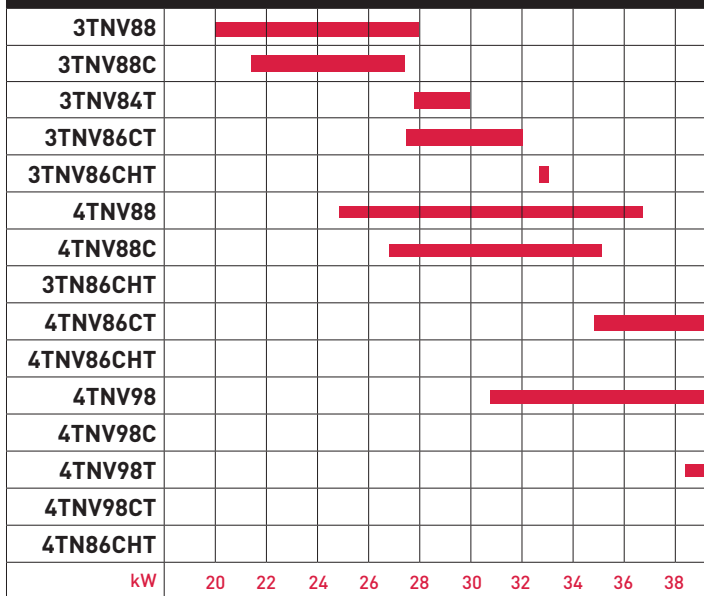

> 56 kW

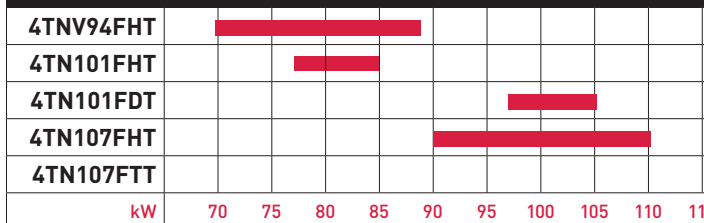

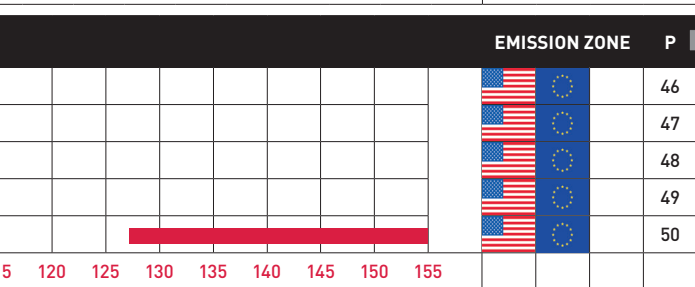
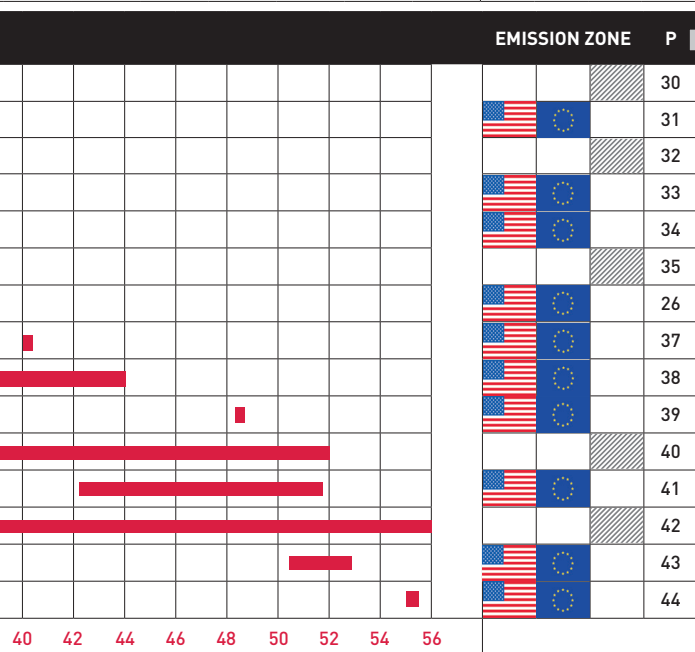
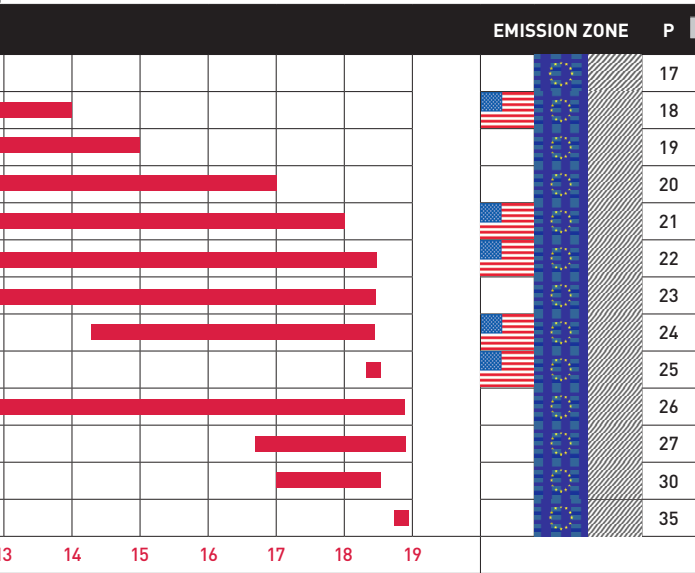

Engine technology

Engines < 19 kW

Engines 19 - 56 kW

Engines > 56 kW

Spare parts

ENGINES < 19 KW

Superlative smoothness in a small industrial engine - due to a flat torque curve- coupled with low fuel consumption, higher power output, reliability and low vibration levels are outstanding attributes of Yanmar's water-cooled engines in the < 19 kW range.

Meeting emissions standards covering the < 19 kW power range, the Yanmar engines offer low lifecycle costs at a high-quality standard.

2TNV70



Emission zone



Displacement [L]
0.570

Max. Output [kW]
10.5

Dimensions [mm]*
L 415
W 427
H 521

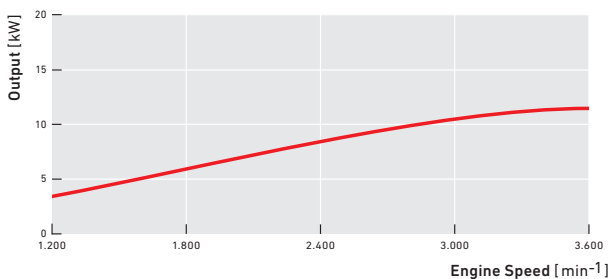
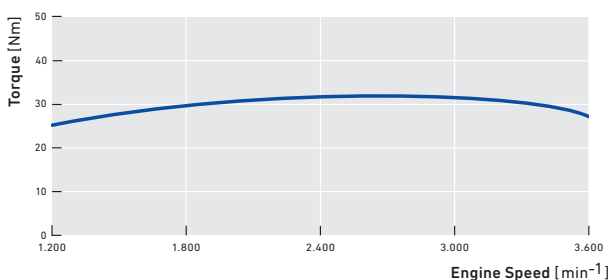

Specification Data Table

Type	-	Vertical cylinder, 4-cycle water-cooled diesel engine
Combustion system	-	Indirect Injection
Aspiration	-	Natural
Fuel Injection system	-	Mechanical
EGR system	-	N/A
Aftertreatment system	-	Non
Available as Power Pack	-	No
Available as Fixed Speed	-	Yes
No. of cylinders	-	2
Bore x stroke	mm	70 x 74
Dry weight*	kg	84

* Dimensions and weight may vary depending on final specifications

3TNV74F

Emission zone



Displacement [L]

0.993

Max. Output [kW]

14.2

Dimensions [mm]*

L 504

W 427

H 506

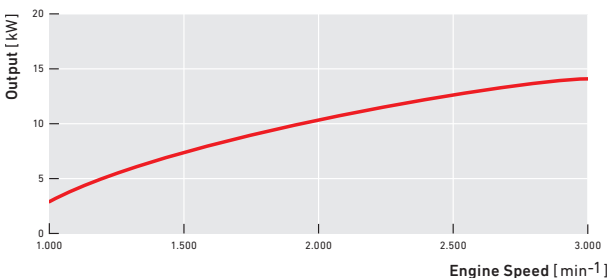
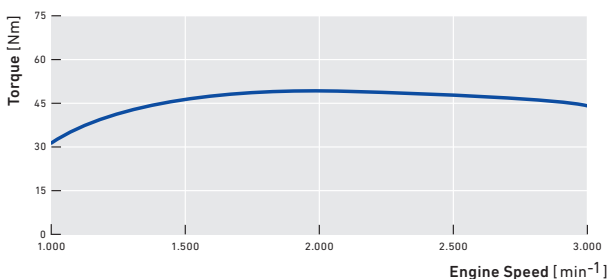
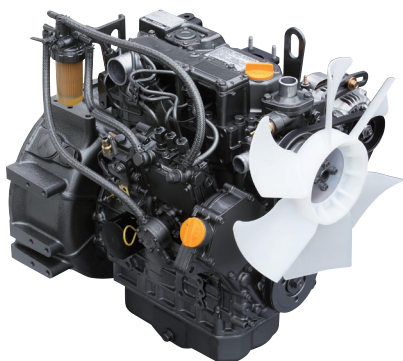

Specification Data Table

Type	-	Vertical cylinder, 4-cycle water-cooled diesel engine
Combustion system	-	Indirect Injection
Aspiration	-	Natural
Fuel Injection system	-	Mechanical
EGR system	-	N/A
Aftertreatment system	-	Non
Available as Power Pack	-	No
Available as Fixed Speed	-	No
No. of cylinders	-	3
Bore x stroke	mm	74 x 77
Dry weight*	kg	103



3TNM68

Emission zone



Displacement [L]

0.784

Max. Output [kW]

14.7

Dimensions [mm]*

L 431

W 416

H 500

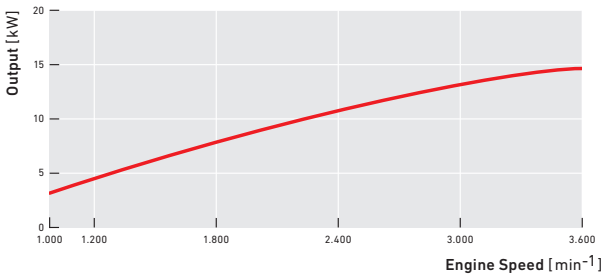
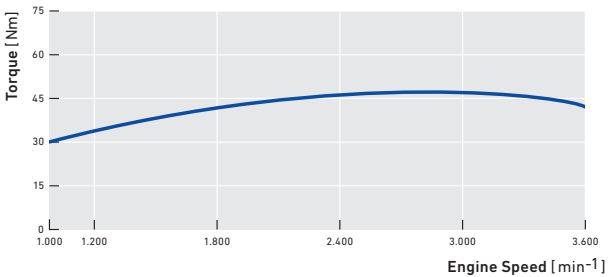

Specification Data Table

Type	-	Vertical cylinder, 4-cycle water-cooled diesel engine
Combustion system	-	Indirect Injection
Aspiration	-	Natural
Fuel Injection system	-	Mechanical
EGR system	-	N/A
Aftertreatment system	-	Non
Available as Power Pack	-	Yes
Available as Fixed Speed	-	Yes
No. of cylinders	-	3
Bore x stroke	mm	68 x 72
Dry weight*	kg	99

* Dimensions and weight may vary depending on final specifications

3TNV70

Emission zone



Displacement [L]

0.854

Max. Output [kW]

17.0

Dimensions [mm]*

L 504

W 427

H 549

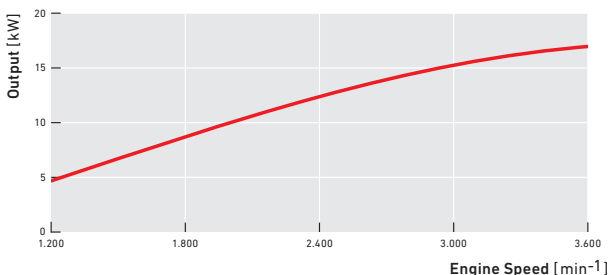
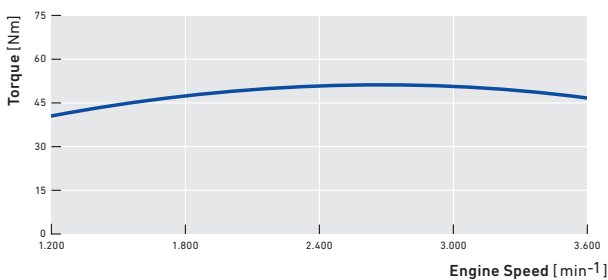

Specification Data Table

Type	-	Vertical cylinder, 4-cycle water-cooled diesel engine
Combustion system	-	Indirect Injection
Aspiration	-	Natural
Fuel Injection system	-	Mechanical
EGR system	-	N/A
Aftertreatment system	-	Non
Available as Power Pack	-	Yes
Available as Fixed Speed	-	Yes
No. of cylinders	-	3
Bore x stroke	mm	70 x 74
Dry weight*	kg	98

* Dimensions and weight may vary depending on final specifications



3TNM74F

Emission zone



Displacement [L]
0.993

Max. Output [kW]
17.8

Dimensions [mm] *
L 450
W 416
H 506

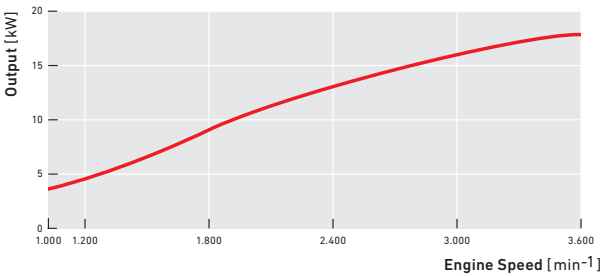
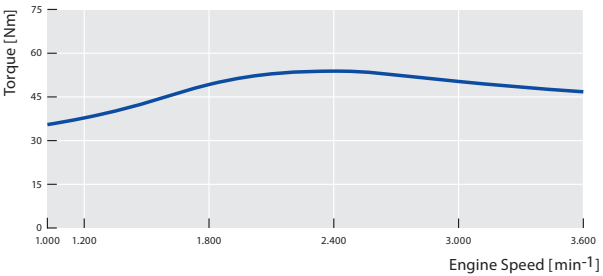

Specification Data Table

Type	-	Vertical cylinder, 4-cycle water-cooled diesel engine
Combustion system	-	Indirect Injection
Aspiration	-	Natural
Fuel Injection system	-	Mechanical
EGR system	-	N/A
Aftertreatment system	-	Non
Available as Power Pack	-	No
Available as Fixed Speed	-	Yes
No. of cylinders	-	3
Bore x stroke	mm	74 x 77
Dry weight*	kg	88

* Dimensions and weight may vary depending on final specifications

3TNV80F

Emission zone



Displacement [L]

1.267

Max. Output [kW]

18.4

Dimensions [mm]*

L 523

W 427

H 532

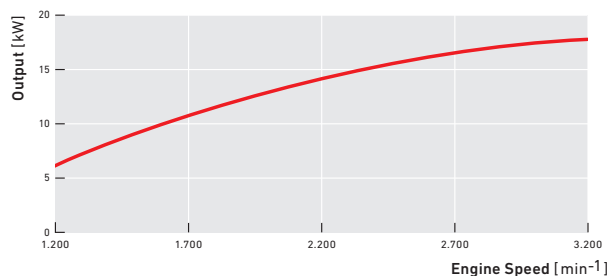
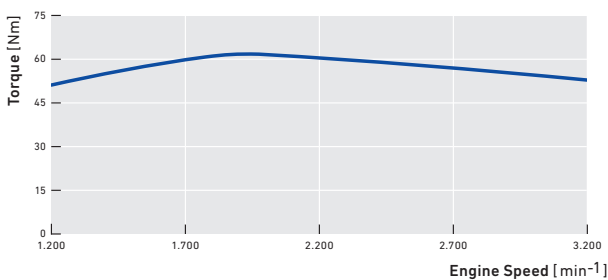
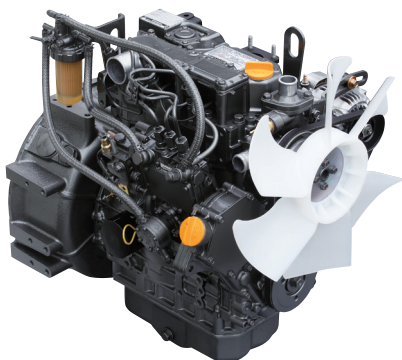

Specification Data Table

Type	-	Vertical cylinder, 4-cycle water-cooled diesel engine
Combustion System	-	Indirect Injection
Aspiration	-	Natural
Fuel Injection system	-	Mechanical
EGR system	-	N/A
After Treatment System	-	Non
Available as Power Pack	-	No
Available as Fixed Speed	-	Yes
No. of cylinders	-	3
Bore x stroke	mm	80 x 84
Dry Weight*	kg	117

* Dimensions and weight may vary depending on final specifications

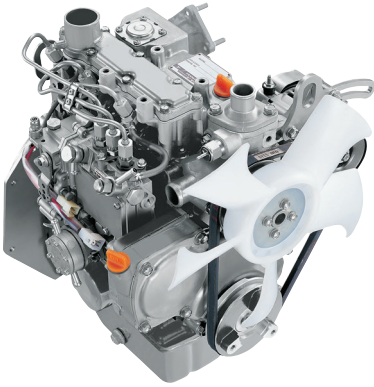

3TNM72

Emission zone



Displacement [L]

0.903

Max. Output [kW]

18.2

Dimensions [mm] *

L 450

W 416

H 506

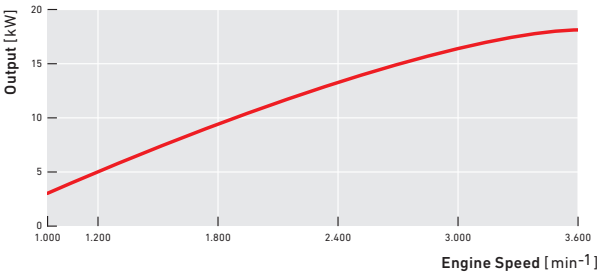
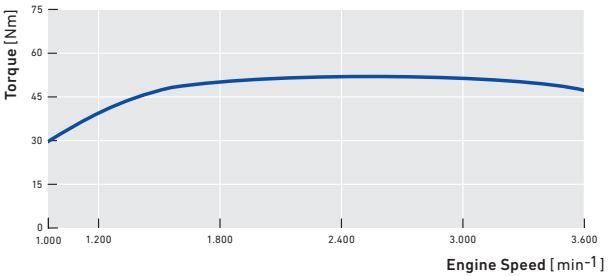

Specification Data Table

Type	-	Vertical cylinder, 4-cycle water-cooled diesel engine
Combustion System	-	Indirect Injection
Aspiration	-	Natural
Fuel Injection system	-	Mechanical
EGR system	-	N/A
After Treatment System	-	Non
Available as Power Pack	-	Yes
Available as Fixed Speed	-	Yes
No. of cylinders	-	3
Bore x stroke	mm	72 x 74
Dry Weight*	kg	105

* Dimensions and weight may vary depending on final specifications

3TNV88F

Emission zone



Displacement [L]

1.642

Max. Output [kW]

18.2

Dimensions [mm]*

L 588

W 577

H 697

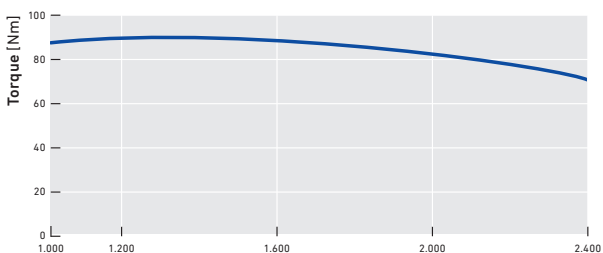

Engine Speed [min⁻¹]

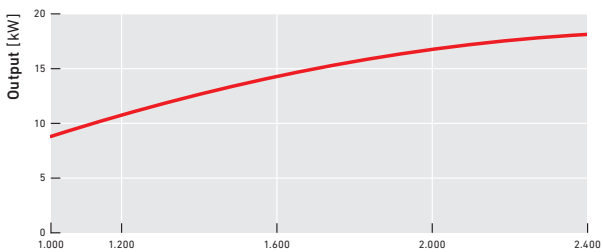

Engine Speed [min⁻¹]

Specification Data Table

Type	-	Vertical cylinder, 4-cycle water-cooled diesel engine
Combustion system	-	Direct Injection
Aspiration	-	Natural
Fuel Injection system	-	Mechanical with electronic governor
EGR system	-	Hot EGR
Aftertreatment system	-	Non
Available as Power Pack	-	No
Available as Fixed Speed	-	Yes
No. of cylinders	-	3
Bore x stroke	mm	88 x 90
Dry weight*	kg	152

* Dimensions and weight may vary depending on final specifications

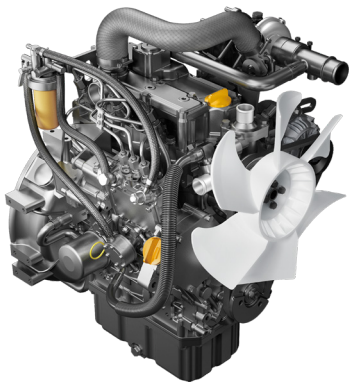

3TNV80FT

Emission zone



Displacement [L]
1.266

Max. Output [kW]
18.4

Dimensions [mm]*
L 545
W 450
H 652

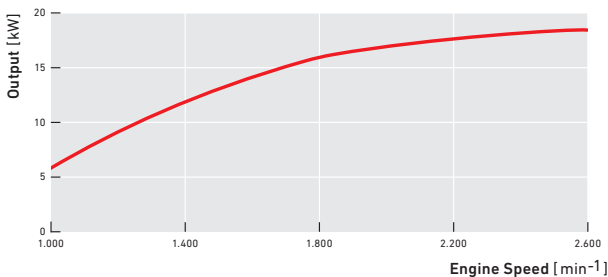
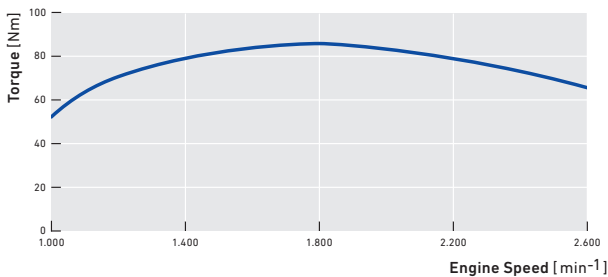

Specification Data Table

Type	-	Vertical cylinder, 4-cycle water-cooled diesel engine
Combustion system	-	Indirect Injection
Aspiration	-	Turbocharged
Fuel Injection system	-	Mechanical with electronic governor
EGR system	-	N/A
Aftertreatment system	-	Non
Available as Power Pack	-	No
Available as Fixed Speed	-	No
No. of cylinders	-	3
Bore x stroke	mm	80 x 84
Dry weight*	kg	121

* Dimensions and weight may vary depending on final specifications

3TNV76

Emission zone



Displacement [L]

1.116

Max. Output [kW]

22.3

Dimensions [mm]*

L 524

W 427

H 572

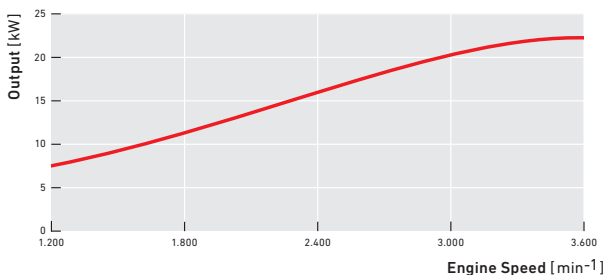
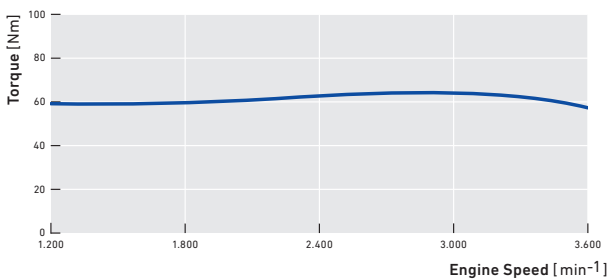
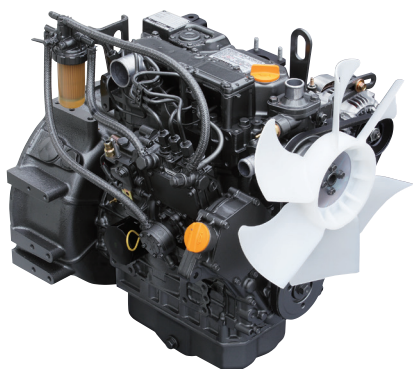

Specification Data Table

Type	-	Vertical cylinder, 4-cycle water-cooled diesel engine
Combustion system	-	Indirect Injection
Aspiration	-	Natural
Fuel Injection system	-	Mechanical
EGR system	-	N/A
Aftertreatment system	-	Non
Available as Power Pack	-	Yes
Available as Fixed Speed	-	Yes
No. of cylinders	-	3
Bore x stroke	mm	76 x 82
Dry weight*	kg	112

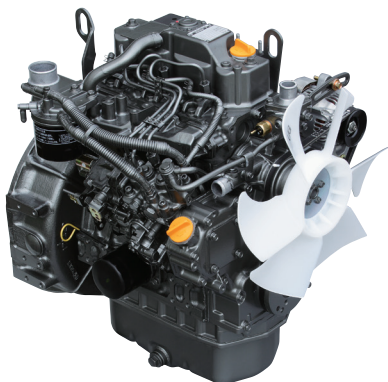

3TNV82A

Emission zone



Displacement [L]
1.331

Max. Output [kW]
23.0

Dimensions [mm] *
L 528.5
W 498.5
H 561

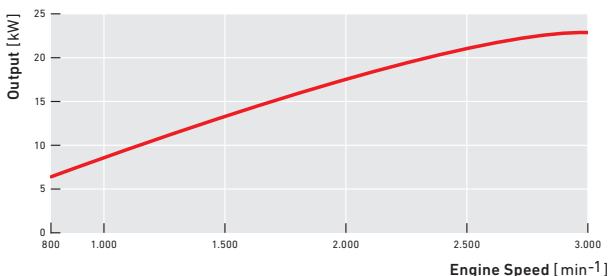
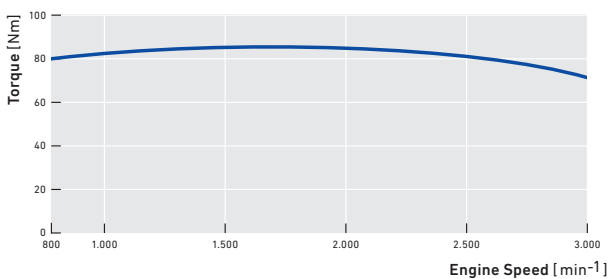

Specification Data Table

Type	-	Vertical cylinder, 4-cycle water-cooled diesel engine
Combustion system	-	Direct Injection
Aspiration	-	Natural
Fuel Injection system	-	Mechanical
EGR system	-	N/A
Aftertreatment system	-	Non
Available as Power Pack	-	No
Available as Fixed Speed	-	No
No. of cylinders	-	3
Bore x stroke	mm	82 x 84
Dry weight*	kg	128

* Dimensions and weight may vary depending on final specifications

ENGINES FROM 19 - 56 KW

In the 19 to 56 kW power range of water-cooled engines a fundamental aspect is the focus on achieving optimal fuel-efficiency without compromising on other features of the models.

The range offers low fuel consumption and high power output, reliability, low vibration and low noise. A flat torque curve delivers unsurpassed smoothness in a small industrial engine which meet world wide regulations.

3TNV88

Emission



Displacement [L]

1.642

Max. Output¹ [kW]

28.1

Dimensions [mm]*

L 564.5

W 517.5

H 622

¹ also available as derated stage V (18.9kW)

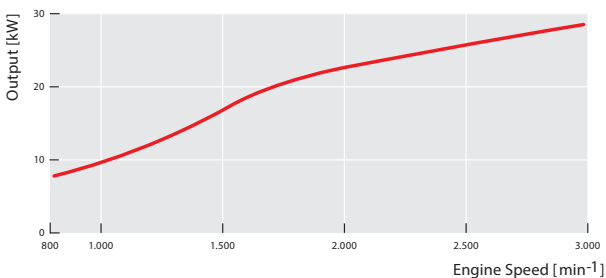
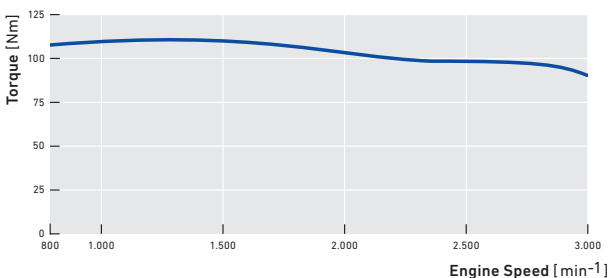

Specification Data Table

Type	-	Vertical cylinder, 4-cycle water-cooled diesel engine
Combustion system	-	Direct Injection
Aspiration	-	Natural
Fuel Injection system	-	Mechanical
EGR system	-	N/A
Aftertreatment system	-	Non
Available as Power Pack	-	Yes
Available as Fixed Speed	-	Yes
No. of cylinders	-	3
Bore x stroke	mm	88 x 90
Dry weight*	kg	148

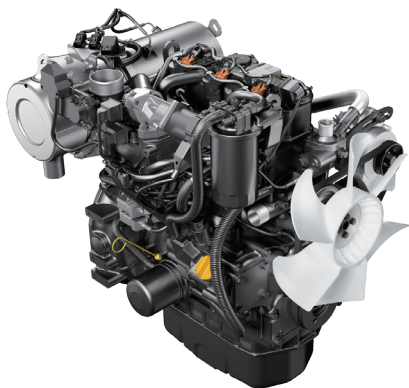

3TNV88C

Emission zone



Displacement [L]
1.642

Max. Output [kW]
27.5

Dimensions [mm]*
L 781
W 541
H 724

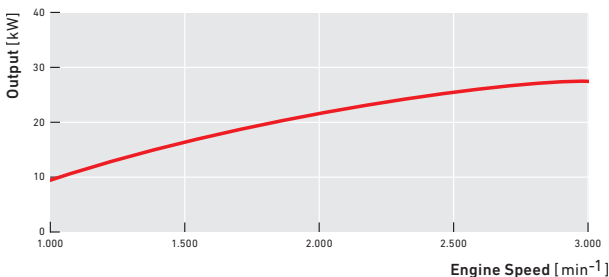
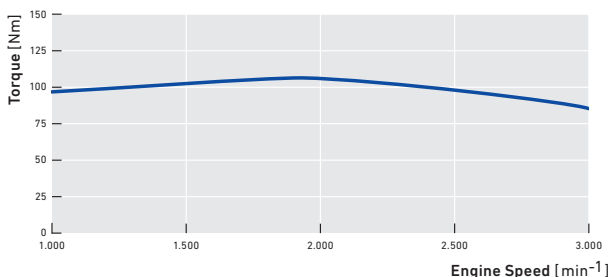

Specification Data Table

Type	-	Vertical cylinder, 4-cycle water-cooled diesel engine
Combustion system	-	Direct Injection
Aspiration	-	Natural
Fuel Injection system	-	Common Rail
EGR system	-	Cooled EGR
Aftertreatment system	-	DOC + DPF
Available as Power Pack	-	Yes
Available as Fixed Speed	-	No
No. of cylinders	-	3
Bore x stroke	mm	88 x 90
Dry weight*	kg	170

* Dimensions and weight may vary depending on final specifications

3TNV84T

Emission zone



Displacement [L]

1.496

Max. Output [kW]

30.1

Dimensions [mm]*

L 615.7

W 517.5

H 652

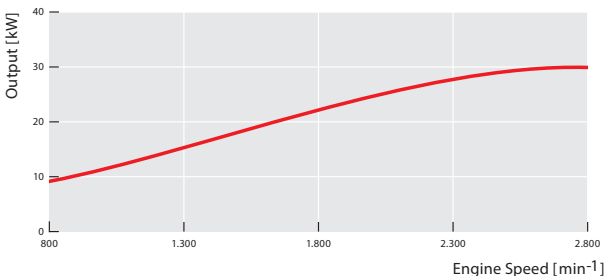
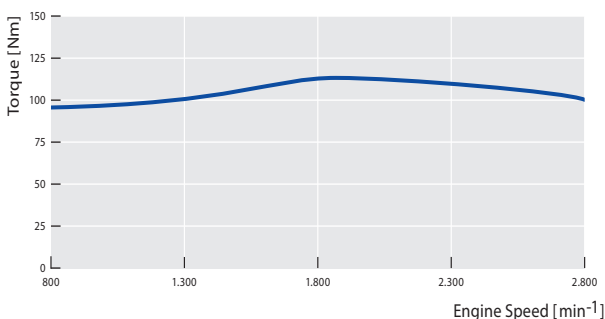

Specification Data Table

Type	-	Vertical cylinder, 4-cycle water-cooled diesel engine
Combustion system	-	Direct Injection
Aspiration	-	Turbocharged
Fuel Injection system	-	Mechanical
EGR system	-	n.a.
Aftertreatment system	-	Non
Available as Power Pack	-	No
Available as Fixed Speed	-	Yes
No. of cylinders	-	3
Bore x stroke	mm	84 x 90
Dry weight*	kg	159

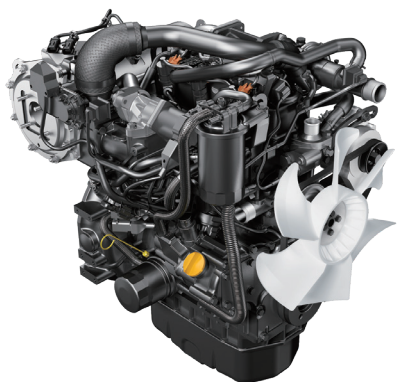

3TNV86CT

Emission zone



Displacement [L]

1.568

Max. Output [kW]

32.4

Dimensions [mm]*

L 781

W 541

H 762

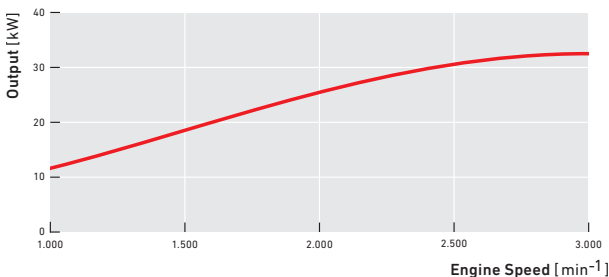
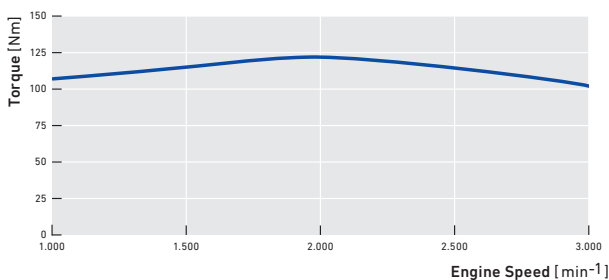

Specification Data Table

Type	-	Vertical cylinder, 4-cycle water-cooled diesel engine
Combustion system	-	Direct Injection
Aspiration	-	Turbocharged
Fuel Injection system	-	Common Rail
EGR system	-	Cooled EGR
Aftertreatment system	-	DOC + DPF
Available as Power Pack	-	Yes
Available as Fixed Speed	-	No
No. of cylinders	-	3
Bore x stroke	mm	86 x 90
Dry weight*	kg	175

* Dimensions and weight may vary depending on final specifications

3TNV86CHT

Emission zone



Displacement [L]

1.568

Max. Output [kW]

33.3

Dimensions [mm]*

L 781

W 541

H 762

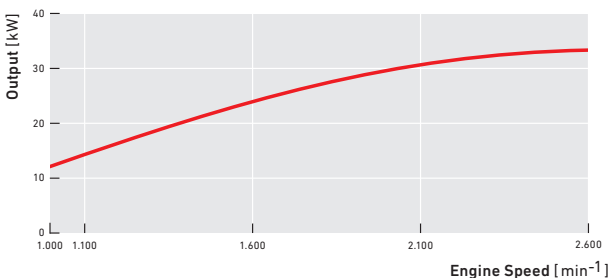
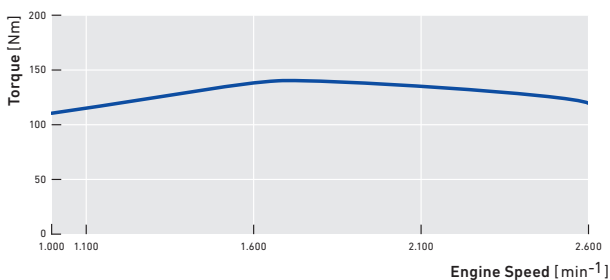

Specification Data Table

Type	-	Vertical cylinder, 4-cycle water-cooled diesel engine
Combustion system	-	Direct Injection
Aspiration	-	T/C with Intercooler
Fuel Injection system	-	Common Rail
EGR system	-	Cooled EGR
Aftertreatment system	-	DOC + DPF
Available as Power Pack	-	No
Available as Fixed Speed	-	No
No. of cylinders	-	3
Bore x stroke	mm	86 x 90
Dry weight*	kg	175

4TNV88

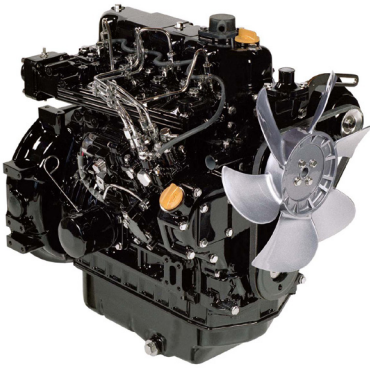

Emission zone



Displacement [L]

2.190

Max. Output¹ [kW]

36.9

Dimensions [mm]*

L 655

W 517.5

H 622

¹ also available as fixed speed stage V (18.9kW)

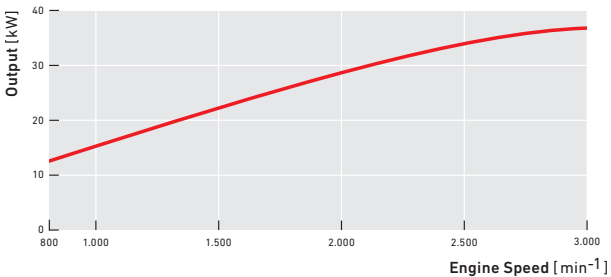
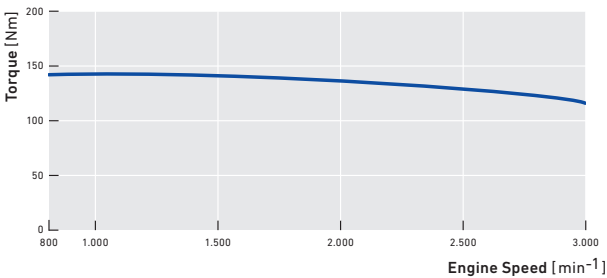

Specification Data Table

Type	-	Vertical cylinder, 4-cycle water-cooled diesel engine
Combustion system	-	Direct Injection
Aspiration	-	Natural
Fuel Injection system	-	Mechanical
EGR system	-	N/A
Aftertreatment system	-	Non
Available as Power Pack	-	Yes
Available as Fixed Speed	-	Yes
No. of cylinders	-	4
Bore x stroke	mm	88 x 90
Dry weight*	kg	165

* Dimensions and weight may vary depending on final specifications

4TNV88C

Emission zone



Displacement [L]

2.190

Max. Output [kW]

35.5

Dimensions [mm] *

L 871

W 541

H 714

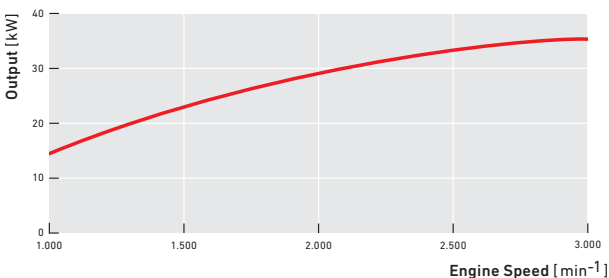
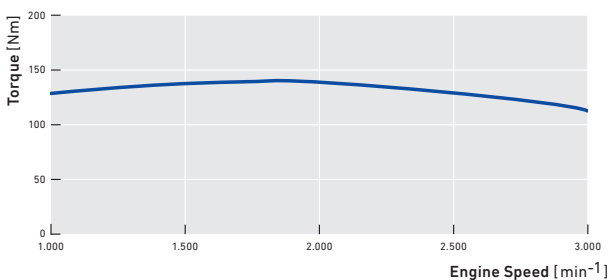

Specification Data Table

Type	-	Vertical cylinder, 4-cycle water-cooled diesel engine
Combustion system	-	Direct Injection
Aspiration	-	Natural
Fuel Injection system	-	Common Rail
EGR system	-	Cooled EGR
Aftertreatment system	-	DOC + DPF
Available as Power Pack	-	Yes
Available as Fixed Speed	-	No
No. of cylinders	-	4
Bore x stroke	mm	88 x 90
Dry weight*	kg	205



3TN86CHT

Emission zone



Displacement [L]

1.568

Max. Output [kW]

40.1

Dimensions [mm]*

L 775

W 541

H 762

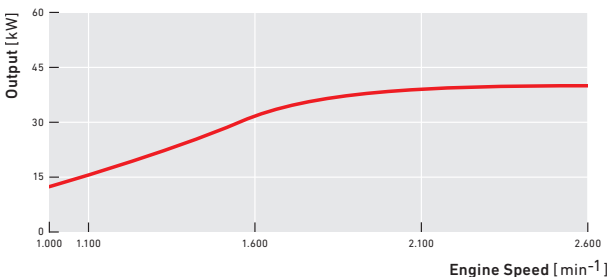
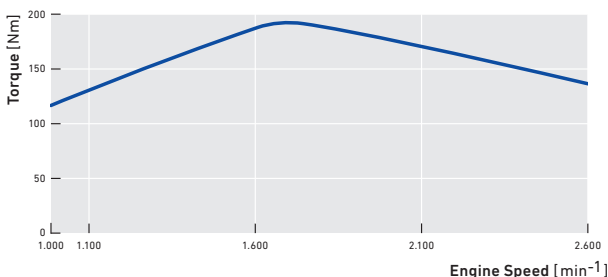

Specification Data Table

Type	-	Vertical cylinder water-cooled diesel engine
Combustion system	-	Direct Injection
Aspiration	-	T/C with CAC
Fuel Injection system	-	Common Rail
EGR system	-	Cooled EGR
Aftertreatment system	-	DOC + DPF
Available as Power Pack	-	No
Available as Fixed Speed	-	No
No. of cylinders	-	3
Bore x stroke	mm	86 x 90
Dry weight*	kg	200

* Dimensions and weight may vary depending on final specifications

4TNV86CT

Emission zone



Displacement [L]

2.091

Max. Output [kW]

44.0

Dimensions [mm]*

L 894

W 549

H 757

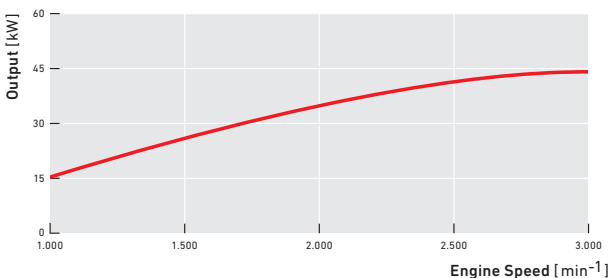
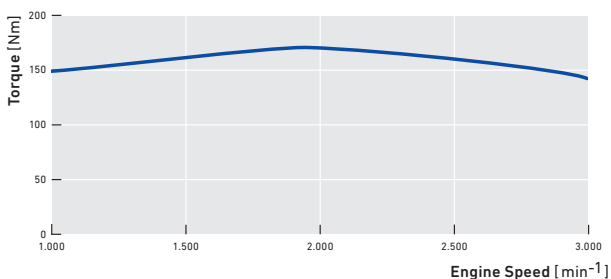

Specification Data Table

Type	-	Vertical cylinder, 4-cycle water-cooled diesel engine
Combustion system	-	Direct Injection
Aspiration	-	Turbocharged
Fuel Injection system	-	Common Rail
EGR system	-	Cooled EGR
Aftertreatment system	-	DOC + DPF
Available as Power Pack	-	Yes
Available as Fixed Speed	-	No
No. of cylinders	-	4
Bore x stroke	mm	86 x 90
Dry weight*	kg	210

* Dimensions and weight may vary depending on final specifications

4TNV86CHT



Emission zone



Displacement [L]

2.091

Max. Output [kW]

48.5

Dimensions [mm]*

L 894

W 549

H 757

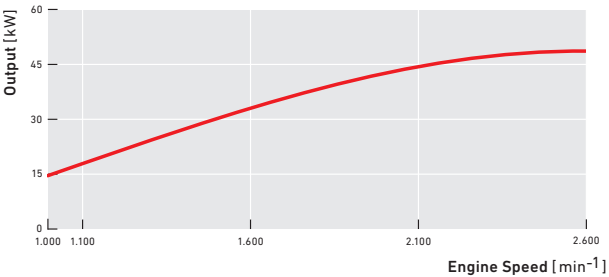
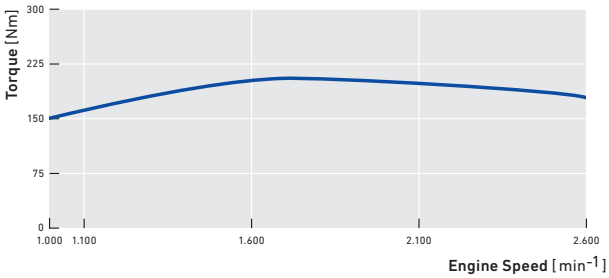

Specification Data Table

Type	-	Vertical cylinder, 4-cycle water-cooled diesel engine
Combustion system	-	Direct Injection
Aspiration	-	T/C with Intercooler
Fuel Injection system	-	Common Rail
EGR system	-	Cooled EGR
Aftertreatment system	-	DOC + DPF
Available as Power Pack	-	No
Available as Fixed Speed	-	No
No. of cylinders	-	4
Bore x stroke	mm	86 x 90
Dry weight*	kg	210

* Dimensions and weight may vary depending on final specifications

4TNV98

Emission zone



Displacement [L]
3.319

Max. Output [kW]
52.1

Dimensions [mm]*
L 719
W 500
H 720

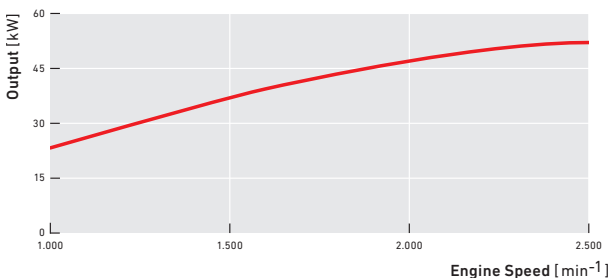
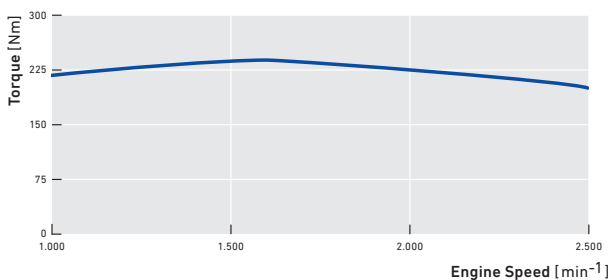

Specification Data Table

Type	-	Vertical cylinder, 4-cycle water-cooled diesel engine
Combustion system	-	Direct Injection
Aspiration	-	Natural
Fuel Injection system	-	Mechanical
EGR system	-	N/A
Aftertreatment system	-	Non
Available as Power Pack	-	Yes
Available as Fixed Speed	-	Yes
No. of cylinders	-	4
Bore x stroke	mm	98 x 110
Dry weight*	kg	274



4TNV98C

Emission zone



Displacement [L]
3.319

Max. Output [kW]
51.7

Dimensions [mm]*
L 983
W 571
H 806

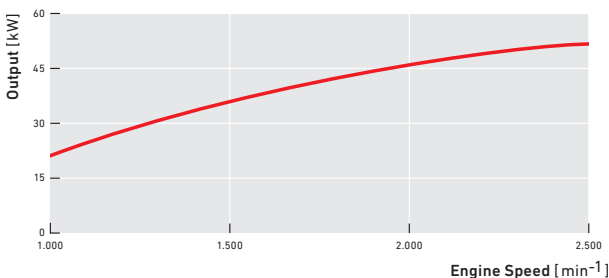
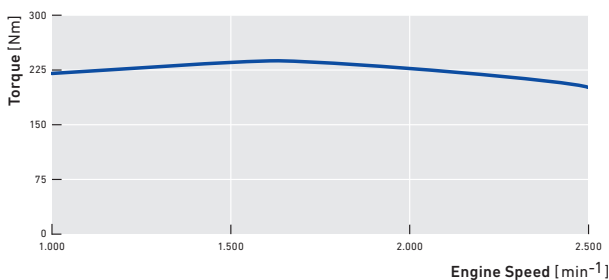

Specification Data Table

Type	-	Vertical cylinder, 4-cycle water-cooled diesel engine
Combustion system	-	Direct Injection
Aspiration	-	Natural
Fuel Injection system	-	Common Rail
EGR system	-	Cooled EGR
Aftertreatment system	-	DOC + DPF
Available as Power Pack	-	Yes
Available as Fixed Speed	-	No
No. of cylinders	-	4
Bore x stroke	mm	98 x 110
Dry weight*	kg	270

* Dimensions and weight may vary depending on final specifications

4TNV98T

Emission zone



Displacement [L]

3.319

Max. Output [kW]

64.1

Dimensions [mm]*

L 719

W 574

H 820

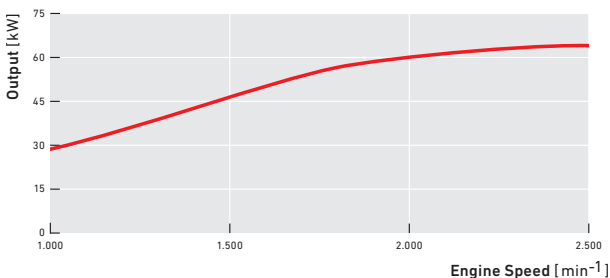
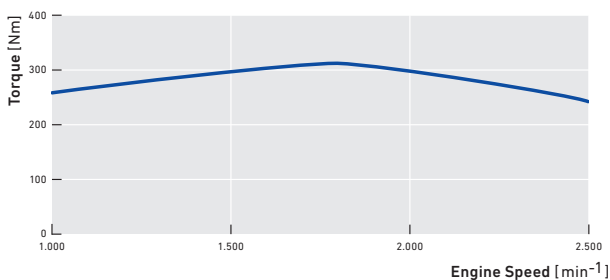
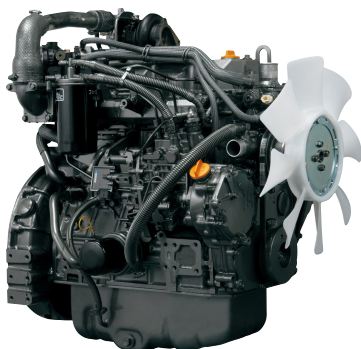

Specification Data Table

Type	-	Vertical cylinder, 4-cycle water-cooled diesel engine
Combustion system	-	Direct Injection
Aspiration	-	Turbocharged
Fuel Injection system	-	Mechanical
EGR system	-	Cooled EGR
Aftertreatment system	-	Non
Available as Power Pack	-	Yes
Available as Fixed Speed	-	Yes
No. of cylinders	-	4
Bore x stroke	mm	98 x 110
Dry weight*	kg	280



4TNV98CT

Emission zone



Displacement [L]
3.319

Max. Output [kW]
53.7

Dimensions [mm]*
L 969
W 600
H 821

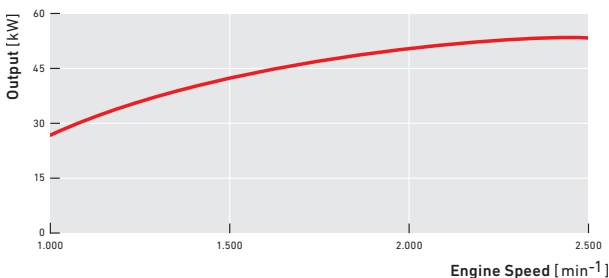
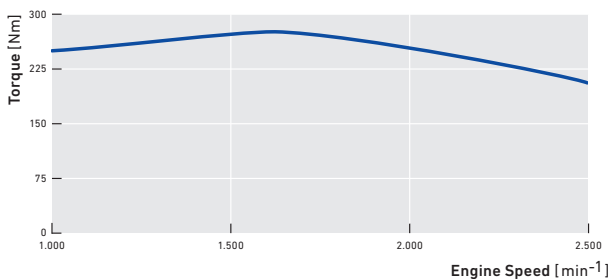

Specification Data Table

Type	-	Vertical cylinder, 4-cycle water-cooled diesel engine
Combustion system	-	Direct Injection
Aspiration	-	Turbocharged
Fuel Injection system	-	Common Rail
EGR system	-	Cooled EGR
Aftertreatment system	-	DOC + DPF
Available as Power Pack	-	Yes
Available as Fixed Speed	-	No
No. of cylinders	-	4
Bore x stroke	mm	98 x 110
Dry weight*	kg	275

* Dimensions and weight may vary depending on final specifications

4TN86CHT

Emission zone



Displacement [L]

2.091

Max. Output [kW]

55.4

Dimensions [mm] *

L 911

W 546

H 760

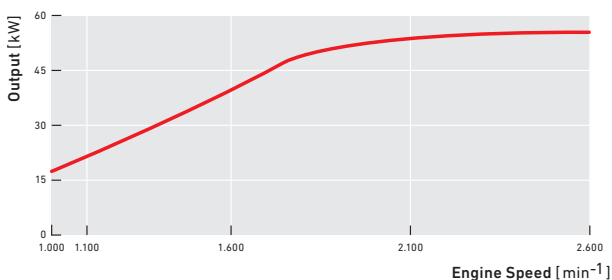
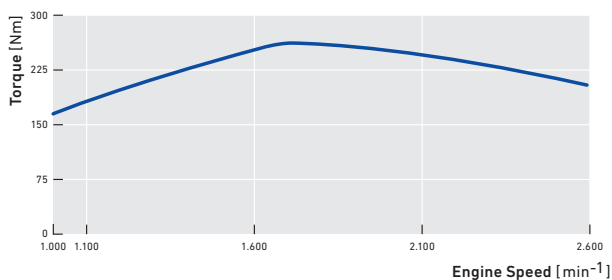
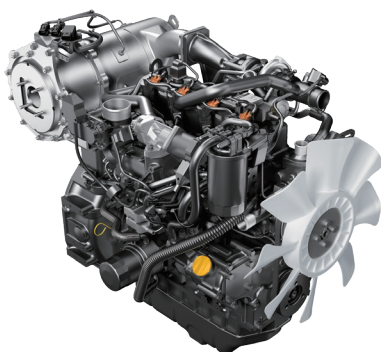

Specification Data Table

Type	-	Vertical cylinder, 4-cycle water-cooled diesel engine
Combustion system	-	Direct Injection
Aspiration	-	T/C with CAC
Fuel Injection system	-	Common Rail
EGR system	-	Cooled EGR
Aftertreatment system	-	DOC + DPF
Available as Power Pack	-	No
Available as Fixed Speed	-	No
No. of cylinders	-	4
Bore x stroke	mm	86 x 90
Dry weight*	kg	247

* Dimensions and weight may vary depending on final specifications

ENGINES > 56 KW

Yanmar engines for the > 56 kW power range offer low fuel consumption and an emphasis on reliability and low noise and vibration levels. A flat torque curve offers exceptional smoothness for a small industrial engine and fuel economy is enhanced using electronically controlled fuel injection fine tuning.

Yanmar engines in the > 56 kW power range offer low emissions, outstanding fuel efficiency, low lifecycle costs and meet world wide regulations.

High Power Engines

In the > 56 kW power range, Yanmar has two high power engines that produce up to 155 kW – the 4TN101 and the 4TN107 – which meet EU Stage V and Tier 4 emissions regulations.

Key features of the 4TN101 and 4TN107 :

- Maximised Uptime
- Best In Class Fuel Consumption
- Wide Power Range
- High Power Density
- Compact Size
- Outstanding Torque

4TNV94FHT

Emission zone



Displacement [L]

3.054

Max. Output [kW]

88.4

Dimensions [mm]*

L 752

W 780

H 1155

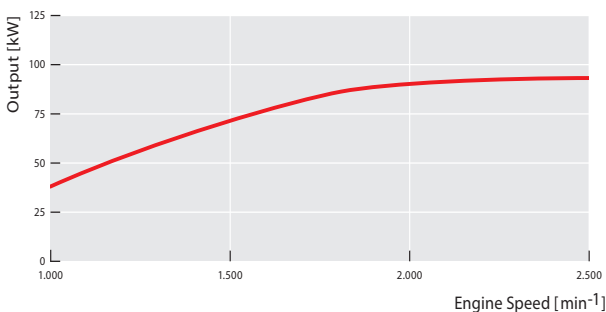
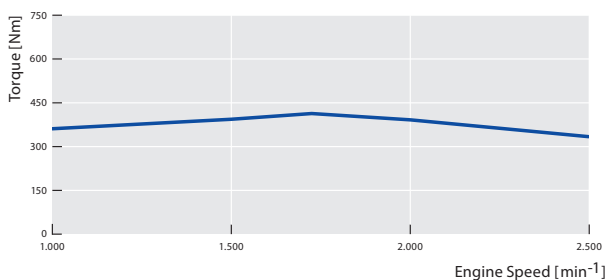
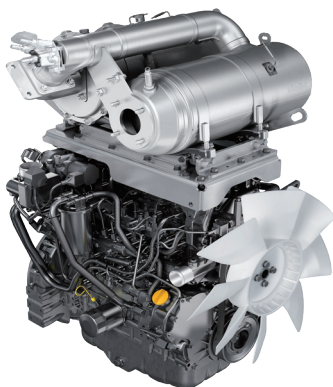

Specification Data Table

Type	-	Vertical cylinder, 4-cycle water-cooled diesel engine
Combustion system	-	Direct Injection
Aspiration	-	T/C with Intercooler
Fuel Injection system	-	Common Rail
EGR system	-	Cooled EGR
Aftertreatment system	-	DOC + DPF + SCR
Available as Power Pack	-	No
Available as Fixed Speed	-	No
No. of cylinders	-	4
Bore x stroke	mm	94 x 110
Dry weight*	kg	370

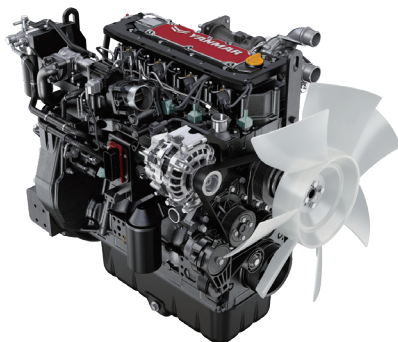

4TN101FHT

Emission zone



Displacement [L]
3.847

Max. Output [kW]
85.0

Dimensions [mm]*
L 955
W 623
H 854

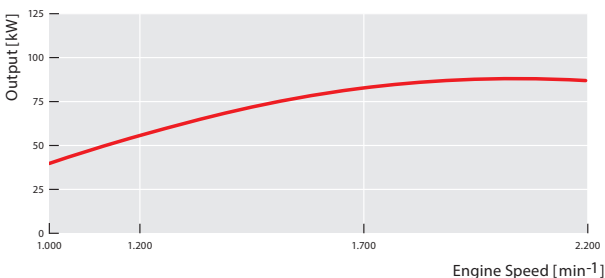
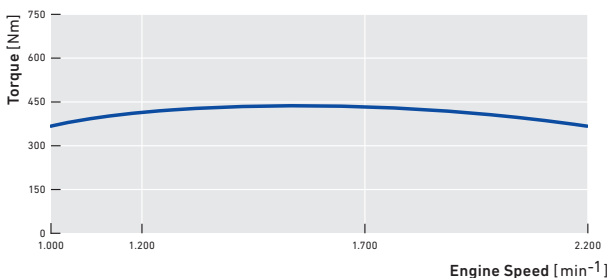

Specification Data Table

Type	-	Vertical cylinder, 4-cycle water-cooled diesel engine
Combustion system	-	Direct Injection
Aspiration	-	T/C with CAC
Fuel Injection system	-	Common Rail
EGR system	-	Cooled EGR
Aftertreatment system	-	DOC + DPF + SCR
Available as Power Pack	-	No
Available as Fixed Speed	-	No
No. of cylinders	-	4
Bore x stroke	mm	101 x 120
Dry weight*	kg	464

* Dimensions and weight may vary depending on final specifications

4TN101FDT

Emission zone



Displacement [L]

3.847

Max. Output [kW]

105.0

Dimensions [mm]*

L 955

W 623

H 854

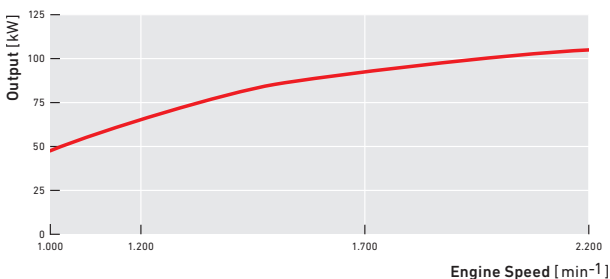
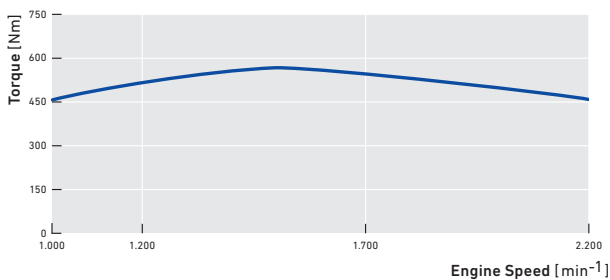

Specification Data Table		
Type	-	Vertical cylinder, 4-cycle water-cooled diesel engine
Combustion system	-	Direct Injection
Aspiration	-	T/C with CAC
Fuel Injection system	-	Common Rail
EGR system	-	Cooled EGR
Aftertreatment system	-	DOC + DPF + SCR
Available as Power Pack	-	No
Available as Fixed Speed	-	No
No. of cylinders	-	4
Bore x stroke	mm	101 x 120
Dry weight*	kg	464

4TN107FHT



Emission zone



Displacement [L]

4.567

Max. Output [kW]

110.0

Dimensions [mm]*

L 972

W 639

H 939

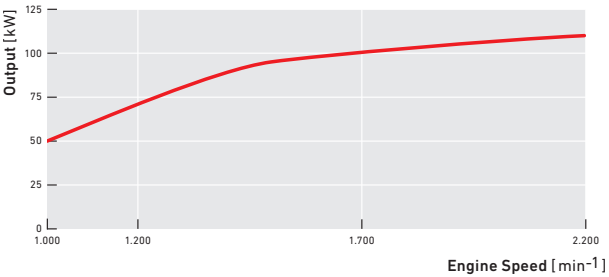
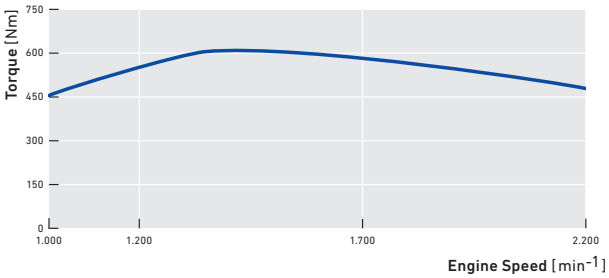

Specification Data Table

Type	-	Vertical cylinder, 4-cycle water-cooled diesel engine
Combustion system	-	Direct Injection
Aspiration	-	Single T/C with Intercooler
Fuel Injection system	-	Common Rail
EGR system	-	Cooled EGR
Aftertreatment system	-	DOC + DPF + SCR
Available as Power Pack	-	No
Available as Fixed Speed	-	No
No. of cylinders	-	4
Bore x stroke	mm	107 x 127
Dry weight*	kg	540

* Dimensions and weight may vary depending on final specifications

4TN107FTT

Emission zone



Displacement [L]
4.567

Max. Output [kW]
155.0

Dimensions [mm]*
L 977
W 443
H 939

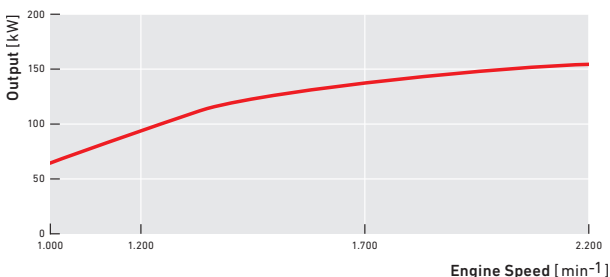
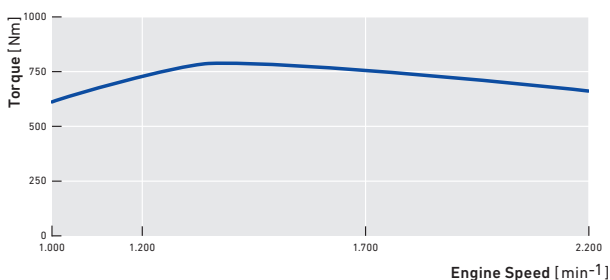

Specification Data Table

Type	-	Vertical cylinder, 4-cycle water-cooled diesel engine
Combustion system	-	Direct Injection
Aspiration	-	Two Stage T/C with Intercooler
Fuel Injection system	-	Common Rail
EGR system	-	Cooled EGR
Aftertreatment system	-	DOC + DPF + SCR
Available as Power Pack	-	No
Available as Fixed Speed	-	No
No. of cylinders	-	4
Bore x stroke	mm	107 x 127
Dry weight*	kg	550



5-YEAR WARRANTY

At Yanmar Europe we know how important continuity is for your business.

As your partner in assuring your business has no downtime, Yanmar now strengthens its promise by providing 5-year (5,000hr) warranty on all new TN series engines.

What's included?

- **DPF/DOC.** Diesel Oxidation Catalysts and Diesel Particulate Filters are included in the 5-year warranty
- **Engine Components.** All parts with standard 2-year warranty now have 5-year warranty
- **Fuel Equipment.** The fuel equipment except for the injector is included in the 5-year warranty
- **Cooling System.** Cooling system and all of its components also have 5-year warranty

The Main Benefits

- Free of charge 5-Year warranty
- Optimal peace of mind
- Covered costs for parts and labor
- Lower cost of ownership

Visit our website for more info:

www.yanmar.com/eu/industrial/5-year-warranty



YANMAR SPAREPARTS

Air Filters

Genuine Yanmar air filters provide optimum filtration of ambient air, so that only clean air, free from dust and other contaminating particles, enters the engine.

Clean air is vital to ensure a lengthy product life, optimum performance, reliable fuel consumption and low emission levels.

Genuine Yanmar air filters protect the engine from wear and keep it within applicable emission standards.

Advantages of Genuine air filters:

- Low fuel consumption and low emission levels
- High dust separation efficiency
- Unchanging high engine performance
- Optimum protection of the engine against wear
- Clean, reliably filtrated combustion air



Fuel Filters

Genuine Yanmar fuel filters offer the guarantee that the diesel that enters your Yanmar engine is absolutely free from harmful water and dirt.

First-class fuel filtration is essential for modern diesel engines to retain excellent performance, comply with high emission standards, and extend product life. Keep your engine in top condition with Genuine Yanmar fuel filters. What else?

- High-density filter paper; water and oil flow repellent
- Micro-fibre design captures variously sized particles
- Effective prevention of clogging prevents wear
- High durability, less interference
- High-capacity fuel filtration for extended product life

Oil Filters

Genuine Yanmar oil filters are made to the highest and most demanding standards. They represent a pledge from Yanmar that the filters will provide state of the art filtration techniques to remove the finest, tiniest particles in lubricating oil.

The result – a healthy and efficient engine offering enhanced up time and increased productivity along with reduced maintenance costs.



Genuine Yanmar Oil Filters help to remove contaminants that can accumulate over time and offer outstanding benefits:

- High dirt absorption capacity
- Reduced maintenance costs
- Safeguard against leakage of unfiltered oil
- Protection against hazardous wear and tear
- Clean oil due to reliable, consistent filtration

Yanmar Engine Oil

The importance of using high quality engine oil and filters cannot be over-estimated. By investing in the best oil and filters the results, and the financial savings to be made, are outstanding.

Clean Oil Equals A Longer Engine Life

Using quality oil is important for a number a reasons: emissions from your engine will be reduced, maintenance costs are slashed and the overall lifespan of the engine is greatly extended.

Yanmar Premium Oil

Yanmar genuine premium 10W30 and 15W40 are tried and tested performance diesel engine lubricants guaranteeing ultimate machine performance.

Opting for cheap, low quality oil can have a potentially disastrous and financially damaging impact on your operations.



Genuine Yanmar engine lubricant offers outstanding benefits:

- Promotes resistance to low temperature sludge and high temperature deposits
- Provides engine corrosion protection and security
- Offers protection against wear and bore polishing
- Formulated to protect against deposits and filter plugging

Coolant

Yanmar genuine high performance long life engine coolant provides protection against freezing, boiling and cooling system corrosion.

The service interval for the long life coolant has been extended to 2,000 hours or two years, whichever comes first, for all TN-series engines.

Benefits of Yanmar's Coolants:

- Antifreeze coolant for extra long life -40°C
- Ready to use
- High performance and ultimate protection
- Package available in 1, 5, 20 and 208 litres



Ready to use filter kits

Adequate maintenance is essential to keep your engine up and running in the best possible condition. With Yanmar's all-inclusive filter kits you can achieve this level of performance without effort.



All required parts and components for servicing are included in one affordable, tailor-made kit in Genuine Yanmar quality. That's what we call: maintenance made easy.

Advantages of an all-inclusive Yanmar filter kit:

- Air filter, fuel filter and oil filter included and attractively priced
- Specified per each Yanmar Industrial engine
- Quick, and hassle-free maintenance inspections
- Reduced downtime and operational costs



REGIONAL OFFICE / SALES & SERVICE

Yanmar Europe B.V.

Brugplein 11, 1332 BS Almere, The Netherlands

T: +31 (0)36 549 3200

E: industrial-yeu@yanmar.com

www.yanmar.com/eu/industrial



EN-TNSERIE-0622