

# SEA SEARCH

## 3.9M - 4.2M

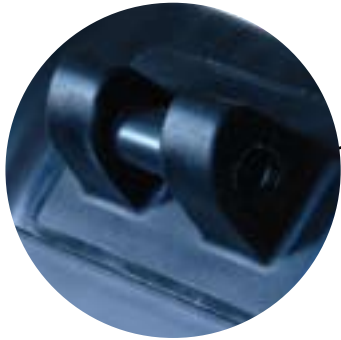

### Bow Roller

The Bow Roller feature enables you to anchor wherever you need to, with an additional cleat handle inside the boat to tie off to.



### Inflatable Keel

All SeaSearch dinghies feature an inflatable keel as standard. It gives better under power and better directional control at speed.

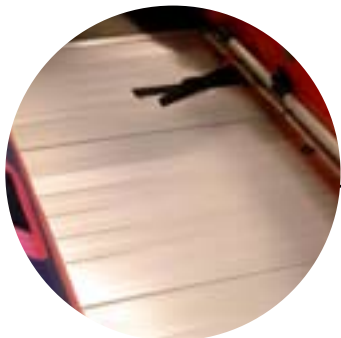

### Aluminium Floor

This anodised double thickness floor is light and durable thanks to its special cavity design. The ribbed patterning gives extra grip underfoot, whilst the sectional design makes it easy to store.



### Handles and Seating

Handles on the inside of the tubes incase of rough conditions. There are also non-slip reinforcement patches for seating and safety.



### Fuel Strap and Oar Clips

The fuel tanks tie down strap keeps the hose neatly to the side preventing a trip or fuel spill hazard whilst the oar clips let you store the oars when an outboard is in use.



**Each supplied with pump, repair kit, seat, oars and transit bag.**

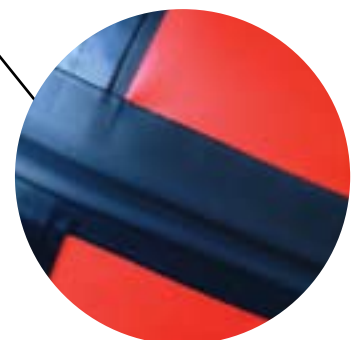

### Rubbing Strake

The double thickness strake is designed to take the knocks and provide the best protection possible for the inflated tube.

# SEAS SEARCH

## SPECIFICATION

	SS390	SS420
Length (mm)	379	418
Beam (mm)	173	201
Tube Ø (mm)	45	53
Internal Width (mm)	81	95
Weight (kg)	68.6	91
Max Persons	5.5	7
Max HP	25	30

### SS390

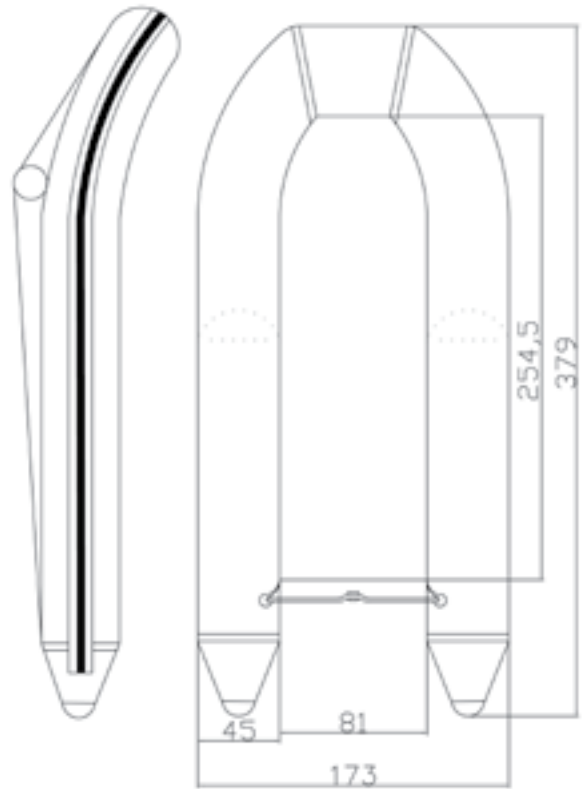

### SS420

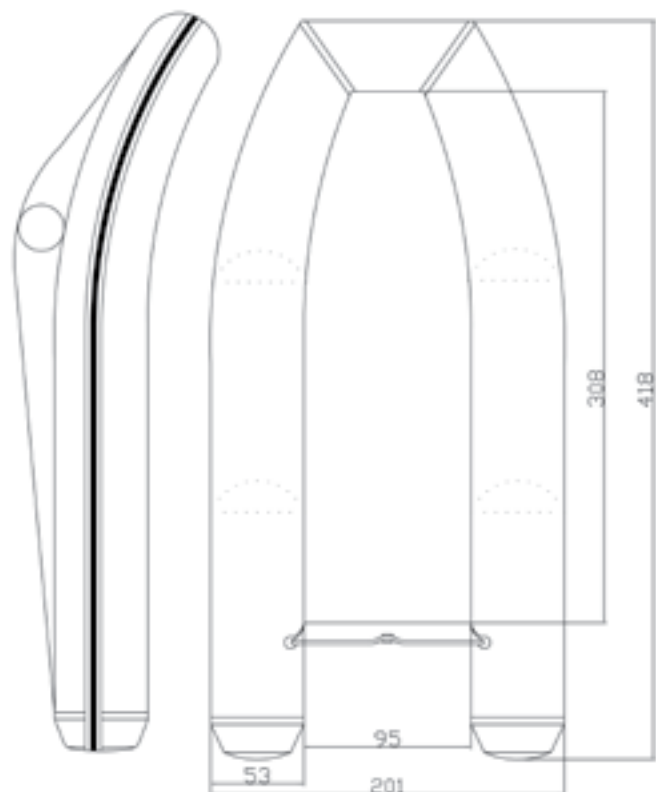

## 2011 PACKAGE PRICES (inc 20% VAT)

SS390 with F15M	£3,369.00
SS390 with F20M	£3,676.00
SS390 with F25M	£4,390.00
SS420 with F15M	£3,655.00
SS420 with F20M	£3,962.00
SS420 with F25M	£4,676.00
SS420 with F30M	£5,105.00



**2 Year Factory Backed Warranty**

**MARINER MERCURY**

**BARRUS**

E. P. Barrus Ltd, Launton Road, Bicester, Oxfordshire, OX26 4UR  
 Tel: 01869 363636 Fax: 01869 363610  
 E-mail: marine@barrus.co.uk www.barrus.co.uk

E. P. Barrus Ltd reserves the right to change specifications and/or prices without notice.